

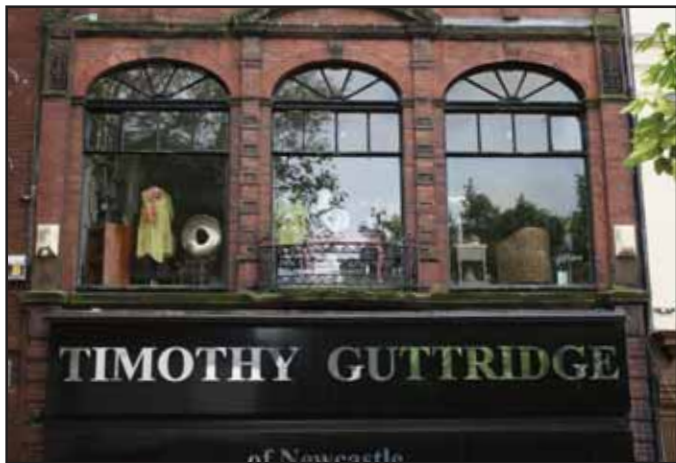

Newcastle-under-Lyme Shop Front Design Guidance



Contents

Introduction	1
Planning permissions, consents and policies	2
Evolution of shop fronts	4
General design principles	4
Elements of a shop front	6
Existing shop fronts	9
New shop fronts	9
Materials, details and colour	9
Adverts - guiding principles	10
Hanging or projecting signs	10
Illumination	11
Security	11
Accessibility	12
Local Register	12
Summary	12
Appendix :	13
Planning policies which may be relevant for shop front design	

Introduction

In the last few years, the character and quality of the town centre has been eroded by unsympathetic alterations, which has an impact on the whole shopping area. To a pedestrian, the most obvious part of a town is often the shop front on the ground floor. Most ground floors in town centres have a commercial use and are vulnerable to change every time businesses change. Some historic shop fronts or features do still survive and should be retained. Attractive, well designed shopping areas encourage shoppers and investment into town centres.

The aim of this guidance is to show owners, occupiers and developers how to improve the visual quality of the area, maintain the special qualities of that area and contribute to the long-term benefit of the commercial area as a whole. It also sets out the basic principles, guidelines and policies the local planning authority will use when assessing applications for new and historic shop fronts and signage but also when assessing other commercial properties such as pubs, banks and other professional businesses. It is also hoped that these principles will help to reverse any adverse alterations and erosion of quality that has taken place over the years especially in the borough's Conservation Areas.

The focus of this guidance is for Newcastle town centre but it should be noted that it is intended to cover the whole borough and all premises at street level, including banks, estate agents and residential conversions.



Planning policy

Planning policies from the Newcastle-under-Lyme and Stoke-on-Trent Core Spatial Strategy 2006-2026 and saved policies from the Newcastle-under-Lyme Local Plan 2011 form the basis of the important considerations the Council will take into account when making decisions about changes to commercial properties, especially those within a Conservation Area or affecting a Listed Building. This guide will supplement and not take away the need for skilled and professional advice. For further information on planning policies which may be relevant to shop front design please see Appendix on page 13.

Planning process

Nearly all changes to a shop front will require planning permission and may also need Advertisement Consent, Listed Building Consent and Building Regulation approval. Information for these permissions and consents is available at www.newcastle-staffs.gov.uk/planning including additional information that is required with any submission such as justification for proposals in a Heritage Asset Statement.

Planning Permission – This is required for any alteration which materially affects the external appearance of the shop front, including installation of blinds/canopies, security shutters, enlarging the size of the fascia or removal/replacement of original elements of an historic shop front where it materially affects its appearance.

Listed Building Consent – If a building affected is a listed building, consent is required for any alterations which affect the character or special interest of that building. Even relatively minor work may also need consent and that may include work to any historic internal fixtures and fittings if they still survive. All work needs to be fully justified in a written statement. **Failure to get Listed Building Consent, if it is required, is illegal.**

Advertisement Consent – Regulations for signs are very specific although some signs can be displayed with “deemed consent” as they are exempt from control. Nearly all illuminated signs require consent as do those above ground floor level, signs on a different wall from the shop front and flags, banners and pole signs. Where

an advert is proposed, details for the consent should include position of the sign on the building, its size, all dimensions, the type of lettering, materials, colour scheme, illuminations and method of illumination.

Displaying an advert without consent is illegal and the Council may prosecute the person responsible. Consent for signage is also time limited and should be renewed.

Building Regulation Approval – Early consultation with building control officers is recommended especially before drawing up proposals for listed buildings. Building Regulation approval is required where proposals involve significant or structural changes to a shop front or any means of escape. Please visit www.stoke.gov.uk for more information.

It is strongly advised that you seek specialist design advice from an architect and the local planning authority before carrying out work to a shop particularly within the Town Centre Conservation Area. No alterations should be done without first gaining the necessary consent. Please note that works to a listed building without Listed Building Consent may be considered a criminal offence which could result in prosecution.





sketch - Forshaw Greaves + Partners, by kind permission

Evolution of shop fronts

Shops were originally part of the ground floor of a house and this would be adapted to what was being sold. Early shops took on the appearance we recognise in the second half of the 18th century – that is a raised window, decorative surround, fascia with the shop name and a central or offset doorway.



Few early shop fronts survive and generally it is later 19th century shop fronts which can be seen today. Clearly some shops were purposely designed buildings but others were modified houses. What is clear is that in general great care was taken to ensure the design and proportion of the building was appropriate to the entire façade of the building.



Shop front designers often showed great craftsmanship and attention to detail. As glass became available in larger sizes, the multi-paned windows were replaced



by larger panes but these were still limited and were often divided up with glazing bars. Large plate glass shop fronts are a modern development.

General principles = Good design that recognises the importance of various elements of the shop front and respects the building and its context.

Scale and proportion

At the design stage, scale and proportion of elements of any new shop front should be paramount. The new shop front should respect and enhance the building which it occupies. No single feature of the shop front should be too dominant.

Quality



In designing a new shop front there should be a commitment to high quality and standards of craftsmanship. Each new shop front should be designed as a whole and not as a mix of components or separate elements with simply applied mouldings. Materials should be of a high quality and the results should be elegant and appropriate.

Context

New shop fronts should be designed to fit in with their wider surroundings or context. Research of a particular character of a street or place should always be carried out to inform the design of any new frontage. For example, is the new shop front within a Conservation Area or does the area have any specific guidance or guidelines for new design? Assessments of the adjacent buildings or shop fronts and prevailing character of the area including age, design, form, detailing and colour should always be done. If the new shop front is to be built in a traditional style, it should be as well informed and historically accurate as possible and appropriate. In summary, it is important to look at the wider street or terrace, stand back and appraise the area from a number of angles. This does not mean design must be uniform; contrasts can also be effective if the rhythm of the buildings is maintained.



Elements of a shop front

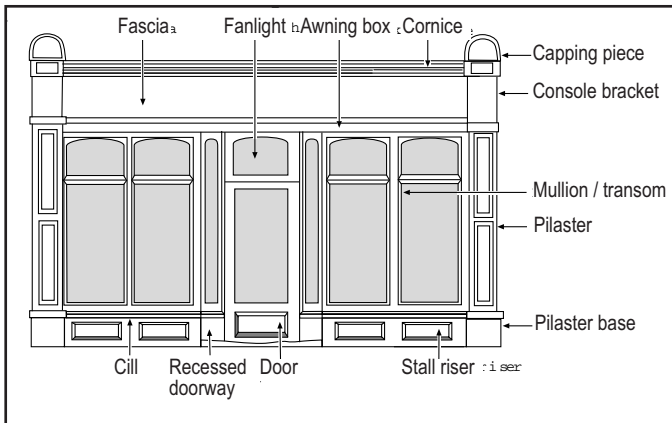

Various elements of a quality shop front all have a particular function. They form a robust frame and provide protection for the goods inside. The frame supports the upper part of the building.

Stallriser – these provide a solid base to a shop front and offer practical protection at low level from damage, water and scuffing. Traditionally the height of stallrisers varies between 450mm and 600mm. Normally they are made from durable material and can be tiles, marble, stone or brick (sometimes rendered). The detail is that they normally have a chamfered or moulded edge. They are also often constructed from painted timber but this is less durable.



Doorways and entrances – doorways traditionally were often recessed and this provides a practical and characteristic feature of a shop front. The entrance was often splayed and set back by at least a metre. The floor



of the entrance was often covered in tiles or mosaic, sometimes with a pattern or the owner's name or business. Doors themselves were often an integral part of the shop front design or complemented it and often had a fanlight which could be open for ventilation or

decoration. The doors often had a solid base to match the stallriser.

Glazing – large undivided areas of glass should be avoided in the majority of cases. Historically the size of the glass was limited and was held in between glazing bars. Window displays should be interesting and changed regularly to stimulate interest and encourage shoppers. In the case of banks, building societies and betting shops etc, it is important to give thought to providing a visual display.





Pilasters – these uprights give the impression of being structural; a visual column marking the end of the shop front which are usually constructed from timber but can be stone or marble. They are based on classical architecture and they have a base or plinth at the bottom providing extra strength and a capping at the top. Pilasters can be plain, panelled or fluted.



Console brackets – this is a bracket usually taking the form of a scroll or other shaped pieces of timber. These are usually topped with a capping, often semi-circular or triangular in shape. These elements frame the fascia.



Fascia – the fascia board is between the console brackets and provides space for advertising the business, its name, trade and number. It is an important design element in the framework of the frontage. They should be kept well below the first floor window and can be flat or angled downwards. The height of the fascia should always be proportionate to the size of the shop front and so should not be excessively deep (generally no more than 600mm deep).

Canopies

Canopies were generally added in the late 19th century, mainly on south-facing shop fronts, and were designed as an integral part of the shop front. In general the individual architectural qualities of the building on which the blind is proposed should be carefully considered. Canvas canopies are considered appropriate if they are integral to the shop front and should retract back fully. Plastic canopies and "Dutch" or balloon blinds are not generally considered appropriate, especially within a Conservation Area, and will be resisted.



Cornice – fascia boards usually have a projection above it in the form of a moulded timber cornice finished with a lead or other metal sheet material (flashing). The depth and size of the cornice usually depends on the size of the shop front.

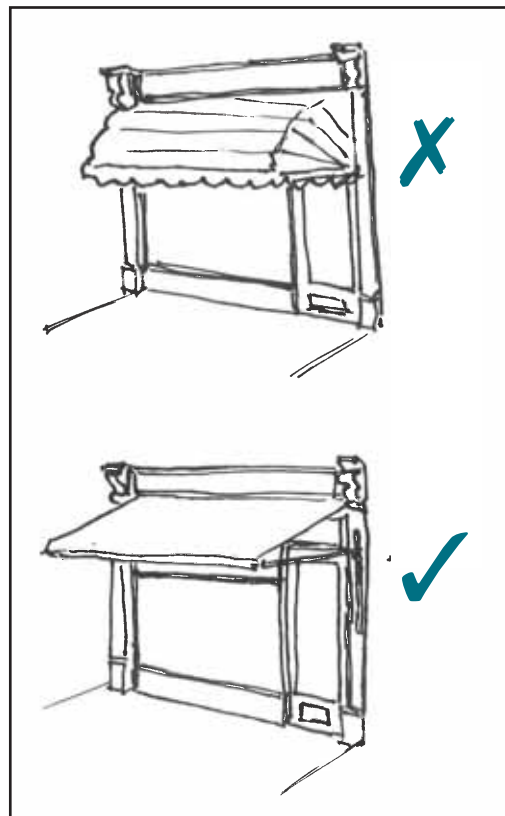

Existing shop fronts

Any proposed alterations to original historic and intact shop fronts will be assessed carefully to ensure that alterations are sympathetic to the character of these features so that the special character is not eroded or compromised. Where elements of original but altered shop fronts remain they should be restored where possible before being replaced. Replacement and reinstatement should be based on appropriate information and photographs if available. Permission will not be given to removal of original shop front elements and it will be expected that they will be incorporated into any new design. Repairs do not require any permission. Maintenance is key - timely repairs on a regular basis can safeguard the condition of buildings and shop fronts. Otherwise major and more costly repairs will be necessary. Derelict buildings or those in need of repair can be an eyesore and harm the overall appearance of a town centre.

New shop fronts



Whether a shop front is a replacement of an existing shop front, or a new opening, a replica of an historic shop front or a contemporary one, the above principles will always apply. Firstly an appraisal is required of the existing shop front. The result should be a shop front which is appropriate to its host building and its context including the design, detailing and general appearance. The outcome of a new shop front based on these principles is that it will enhance the environment of the street by being well designed and of high quality. An attractive shopping environment generally will increase

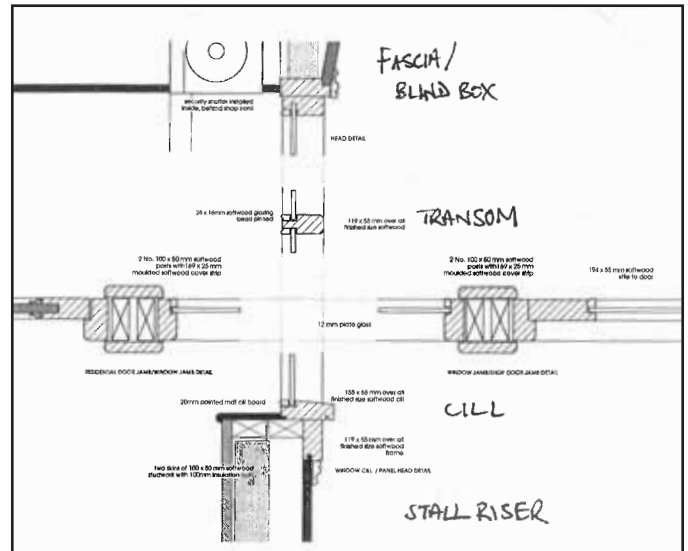

trade and have a positive effect on economic regeneration. Any modern shop front should still reinterpret the proportions and form of adjacent shops, but in a contemporary manner. If materials are marketed as maintenance-free, this usually means that when they wear out they need to be replaced and cannot be repaired, which is more expensive in the long run.

Materials, details and colour

Traditional shop fronts were constructed from timber and had a painted finish. Carpentry and craftsmanship were essential parts of the construction of any shop front. Materials of new shop fronts should ideally be well-seasoned good quality softwood. Colour is



important and the sensitive use of colour offers scope for improving the appearance of the streetscene. Generally rich, deep colours often look good particularly when used on traditional shop fronts. The use of other colours to highlight details can also be effective. The colours that were available



- They should relate architecturally to the building on which they are part and should not dominate the shop front or building but respect its scale and proportion
- They should be sympathetic to the surrounding scale and streetscene
- They should be constructed from durable, appropriate materials
- The typeface or font for the lettering, its layout and design should be legible and simple

Fascia signs are perhaps the most prominent and effective form of advertising and they do fulfil an important role in communicating the business.



They are the most prominent element of a shop front and therefore the position and design can either create clutter or enhance the streetscene. The fascia advert should be in harmony with all other elements of the frontage and it should not obscure windows or other architectural details. In general simple and contrasting lettering will be the most legible. In the Conservation Area, a timber fascia with applied or painted letters is the most appropriate. Acrylic or shiny materials and reflective lettering will be resisted and where this is currently found, when a change is proposed a better quality material should be chosen. Box fascias should be avoided.

and affordable in the 19th and 20th centuries were limited - dark hues were the most practical. A high gloss finish is more resistant to damage. Corporate colours will be considered but they must be appropriate.

Advertisements

The main kinds of advertisements are fascia signs, projecting or hanging signs and wall mounted signs and "A" boards. Adverts can be harmful to the building where they are displayed or harm the street if the style, lettering, colours or illumination are ill-considered.

Guiding principles -

- Adverts should be designed in scale and in proportion with the shop front and the building of which the shop front is part of
- They should be to a high standard of design

Hanging or projecting signs

Traditionally a hanging sign was designed to swing and modern hanging signs often mimic these but are static. They can provide a visually interesting and important element of advertising but if too many are found along



Illumination

Illuminated signs will be resisted in Conservation Areas except Newcastle town centre and the commercial part of Audley village because some illumination can be beneficial to the night-time economy. The Council will still ensure that all advertisements are sensitive to their environment and enhance the area. Generally illumination should be necessary, subtle and an integral part of the fascia or shop front either by illuminating individual letters or logo or by "halo" illumination if it complements the design of the shop front. Internally illuminated box fascia or other signs will not be considered acceptable. Any external illumination should be the minimum amount necessary and be discreet. Neon lighting will be resisted as being inappropriate as will flashing or moving illumination.

one location, they can cause a cluttered appearance. This then undermines the principle of the advert attracting the attention of the passer by. The hanging sign should not undermine the appearance of the building, should be appropriately sized and if existing brackets survive they should be re-used. Hanging signs should not be a hazard to pedestrians or vehicles and there should be only one hanging sign per shop. It should not be assumed that every shop can display a hanging sign; they will be carefully controlled, so this should be justified to the local planning authority. Internally illuminated hanging signs are not considered acceptable.

Security



It's obviously very important to owners that their properties are secure but security can be carried out without the need for solid external roller shutters which are not permitted in Conservation Areas. During the day solid shutters create an unattractive and harmful appearance. At night the atmosphere it creates can be intimidating, encourage graffiti and is generally less attractive.

The preferred method of shop security is toughened or laminated glass or lattice shutters installed internally. Neither of these methods require planning permission. Other security methods such as CCTV can be a good deterrent and complement other measures to protect entry points to buildings. Window mullions to reduce the size of the panes of glass also give additional

Other adverts – some businesses and shops have a tendency to over advertise and have too many signs - this shows a lack of respect for the character of the streetscene. This includes "A" boards which are often placed outside a shop, outside alleyways or in locations that are nowhere near the shop. "A" boards are often not on private land but are part of the highway and can be a hazard to pedestrians, especially those with pushchairs, those in wheelchairs and the visually impaired. This is the case in parts of Newcastle town centre but they are controlled by Staffordshire County Council. All advertising should be carefully considered and respect the streetscene.

strength to shop fronts. Simple wrought iron gates can be used to secure doorways. These external additions will require planning permission.

All security systems should feature an open lattice or perforated design, be located back from the display window and painted appropriately, perhaps to co-ordinate with an existing colour scheme. External shutters will be resisted but might be considered acceptable if they are of lattice type, only cover the glass instead of the whole shop front and the box is fully recessed into the shop front.

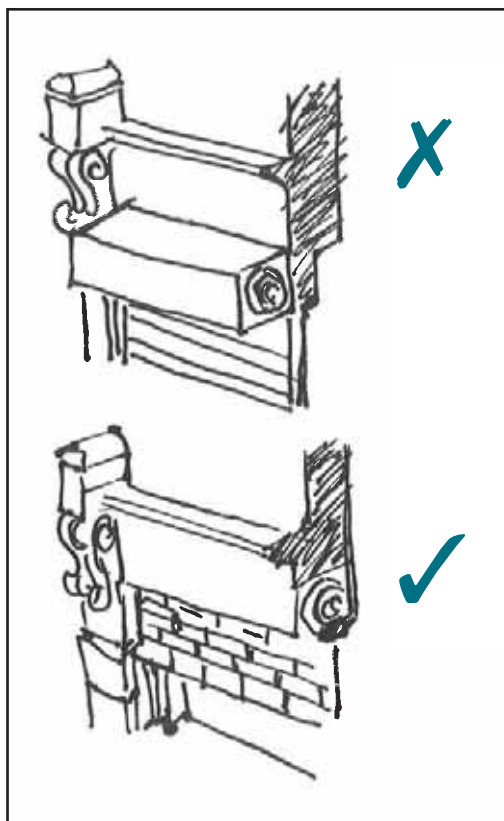

Accessibility

New shop fronts should enable people to gain access easily. Steps should be avoided but access should also be provided without detriment to the character and design of the shop front. Early discussion is advised with the local planning authority and it is recommended to carry out an independent access audit by a qualified person.

Ideally the entrance to the shop should be designed to be level with the pavement. If this is not possible a non-slip ramp (maximum gradient 1:12) should be provided

or a secondary access point. Whilst it is important to ensure access for all through the main entrance of all buildings, that access should be provided without detriment to the character and design of the shop front. Where the access affects a listed building it is important that there is early discussion with the local planning authority - the disability discrimination requirements need to be reconciled to decide what the impact is on the special character and appearance of the building. For visually impaired people, the entrance can be emphasised through colour and textual contrasts. Overall, the local planning authority will seek to retain the unique character of buildings within the borough.

Buildings on the Local Register

The Council maintains a Register of Locally Important Buildings and will consider including historic shop fronts to encourage preservation of worthy features. This does not give the Council extra statutory powers to protect these elements specifically; it will ensure that the value of the building and its elements is recognised and valued where possible, including consideration of grant aid.

www.newcastle-staffs.gov.uk/localregister

SUMMARY

- Decide new or alter existing
- Appraise building and consult architect
- Discuss with the Council if there are any specific consents or requirements
- Prepare design
- Make planning application/advertisement consent
- Building regulations
- Following consent, tender from builders
- Install shop front /start repairs or alterations

Appendix : Planning policies which may be relevant for shop front design

Newcastle-under-Lyme and Stoke-on-Trent Core Spatial Strategy 2006-2026

CSP1 – Design Quality

CSP2 – Historic Environment

Newcastle-under-Lyme Local Plan 2011 (saved policies)

- B5: Control of development affecting the setting of a Listed Building
- B6: Extension or alteration of Listed Buildings
- B9: Prevention of harm to Conservation Areas
- B10: The requirement to preserve or enhance the appearance of a Conservation Area
- B13: Design and development in Conservation Areas
- B14: Development in or adjoining the boundary of Conservation Areas
- B16: Shop fronts in Conservation Areas
- B17: Awning, canopies and blinds in Conservation Areas
- B18: Security shutters in Conservation Areas
- B19: Illuminated signs in Conservation Areas
- B20: Illuminated fascia and other signs in Conservation Areas

